

Detail I
Scale (10:1)

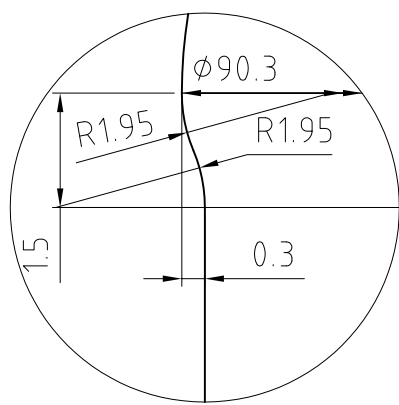

Detail Y
Scale (10:1)

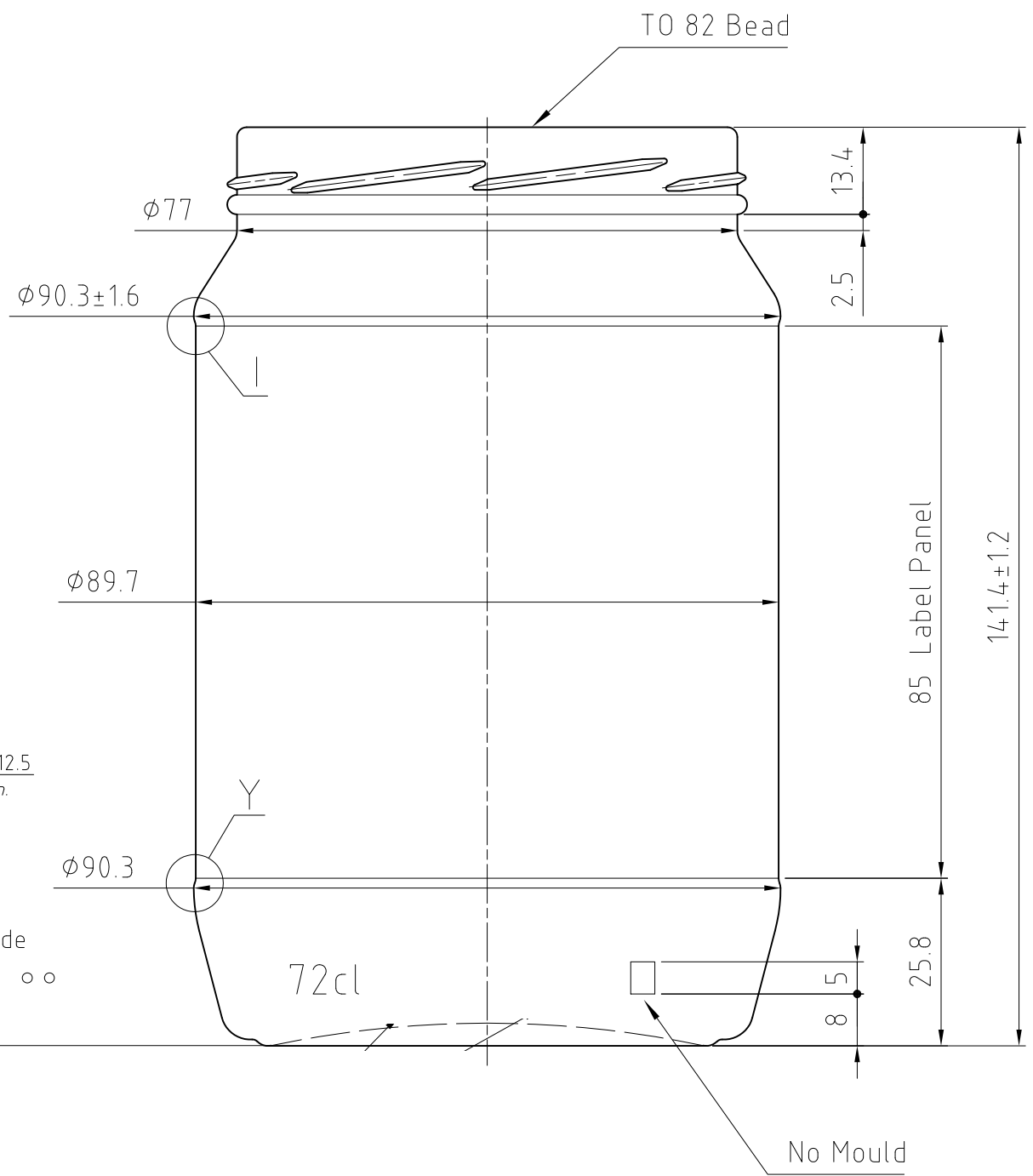
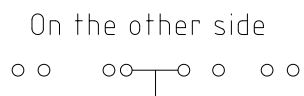
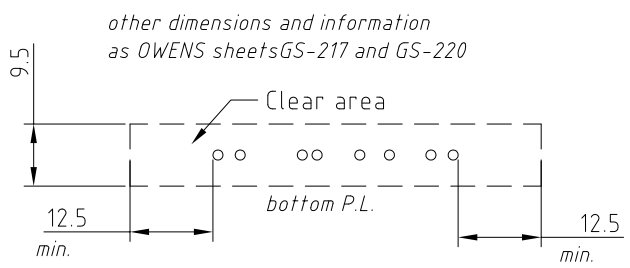
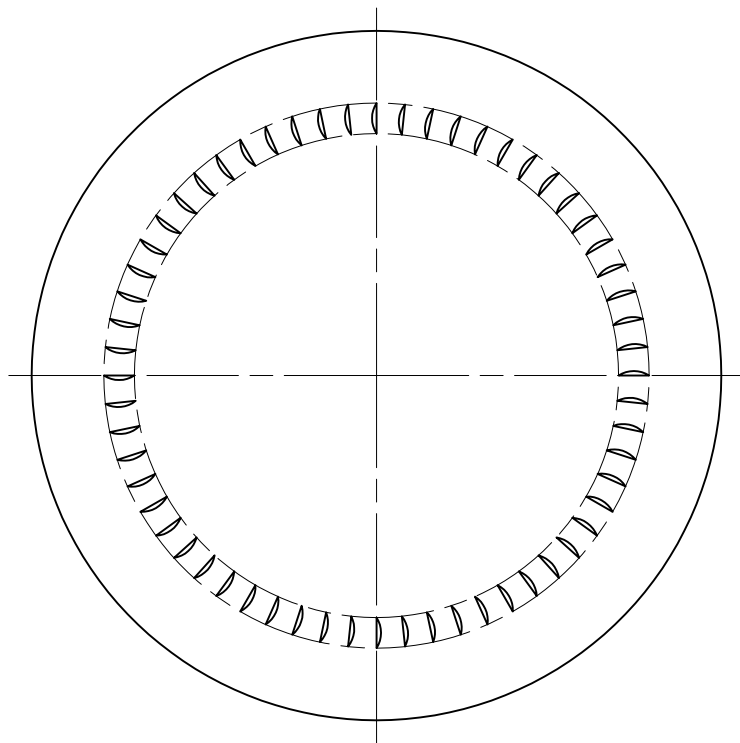
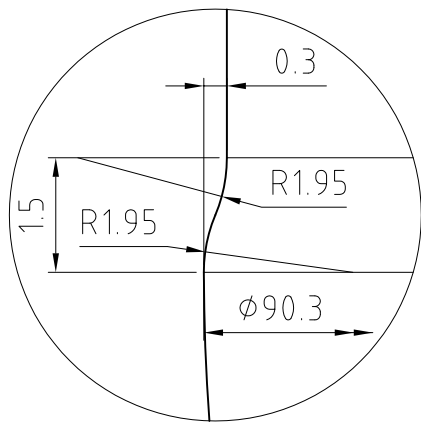

NAME	DATE	REVISIONS	MOLD NO.			A3	
			FINISH	FIN 074			
			CAP. BRIMF.	720±10ml	MACHINE	DG 5 1/2"	BOTTLE
			CAP. FILLPT.		DATE	24/01/2006	72cl JAR
			FILL LINE		DRAWN	Stanchev	CAT.No & DWG No
			WEIGHT	285gr	CHECKED	Angelov	8443074
			COLOR	FLINT	CONFIRMED		SHEET: 1/1 SCALE: 1:1